

India's Biggest Travel Show Network



**14 15 16 July 2023**

Biswa Bangla Mela Prangan (Hall - B)  
**KOLKATA**

## EXHIBITOR'S INFORMATION & ORDER BOOK

CONTENTS	PAGE
<b>A. Useful Show Information</b> Venue details, Opening hours, Show Secretariat / Organiser, Contact persons, Freight forwarder etc.	2
<b>B. Exhibition Hall Specifications</b>	3 - 5
<b>C. Record of Orders &amp; Order Forms</b> (Forms 1 to 4)	6 - 9
<b>D. Awards Programme &amp; Forms</b> (Forms 6A to 6E)	10 - 15
<b>E. Final Checklist &amp; Show Implementation</b>	16 - 17

**INDIA'S BIGGEST TRAVEL  
SHOW NETWORK**

KOLKATA • AHMEDABAD / GANDHINAGAR • HYDERABAD  
DELHI • MUMBAI • BENGALURU • CHENNAI

## A. The Exhibition

Travel and Tourism Fair (TTF)

### A1. Venue

**Biswa Bangla Mela Prangan (Hall - B)**

Beside ITC Sonar Bangla

### A2. Hours & Dates

Thursday	13 July	16:00 - 20:00 hrs	Registration & Booth set-up
Friday	14 July	08:00 - 10:00 hrs	Registration & Booth set-up
		11:30 hrs	Inauguration
		11:00 - 19:00 hrs	Trade only
Saturday	15 July	11:00 - 14:00 hrs	Trade only
		14:00 - 19:00 hrs	Open for all
Sunday	16 July	11:00 - 19:00 hrs	Open for all
		19:00 - 20:00 hrs	Dismantling of booths & removal of exhibits

**Participants will not be allowed to leave their stall before the official closing time everyday.**

**The Hall will not be open overnight for booth construction/set-up, due to security considerations.**

### A3. Show Secretariat/Organiser

**Kolkata** : 25 C/1 Belvedere Road, Alipur, Calcutta 700 027

Tel : (91) (33) 4028 4028

**Mumbai** : 305, 3rd Floor, The Summit Business Bay, Near WEH Metro Station, Off Andheri Kurla Road

Andheri (E), Mumbai 400 093

Tel : (91) (22) 4555 8555

**New Delhi** : U-1 Basement, Green Park Main, New Delhi 110 016

Tel : (91) (11) 4615 0947

**Ahmedabad** : Room No. 204, Eternia Complex, Behind City Center, Swastik Cross Road, C G Road,

Navrangpura, Ahmedabad 380 009 Tel : (91) (79) 2646 1217

**Bengaluru** : 2454, 17th 'E' Cross, 9th Main, Ground Floor, Banashankari, 2nd Stage Bangalore 560 070

Tel : (91) (80) 2676 1598

E-mail : [contact@fairfest.in](mailto:contact@fairfest.in) URL : [www.ttfotm.com](http://www.ttfotm.com), [www.fairfest.com](http://www.fairfest.com)

Contact : Tarique Ebrahim - (91) 9831075090

Rajarshi De - (91) 9007780788

### A4. Recommended Air Cargo

**BLUE DART EXPRESS LTD**

Web : [www.bluedart.com](http://www.bluedart.com)

Toll Free No. 1860 233 1234

### A5. Recommended Surface/Air Cargo

**GATI LTD.**

Web : [www.gati.com](http://www.gati.com)

Toll Free No. 1860-123-4284

## **B. EXHIBITION HALL**

### **B1. CONSTRUCTION OF BOOTH**

Exhibitors must ensure that all parts of their work are self supporting and secure.

**Kolkata** : Exhibitors who have ordered bare space may begin building their booths 23:00 hours on 12 July and all work should be completed by 20:00 hours on the following day.

**The Hall will not be open overnight for booth construction/set-up, due to security considerations.**

### **B2. MOVE IN OF EXHIBITS**

**Kolkata** : Exhibitors who have ordered bare space and shell may move in their exhibits from 16:00 hours on 13 July and all work should be completed by 10:00 hours on the following day.

Exhibitors must arrange for an authorised representative to be present at the site to receive and position goods as the organiser is unable to accept delivery.

**The Hall will not be open overnight for booth construction/set-up, due to security considerations.**

### **B3. DISMANTLING AND REMOVAL OF EXHIBITS**

**Kolkata** : Exhibits must be moved between 19:00 hours and 23:00 hours on Sunday, 16 July 2023  
**Dismantling of booths is prohibited before the close of the exhibition.**

Removal, delivery or replenishment of stock may only be carried out before the opening hours of the exhibition in the morning or after closing time in the evening. If the removal of any valuable item or display from the hall is necessary, Exhibitors must obtain permission from the Organiser.

## B4. STANDARD SHELL SCHEME BOOTH

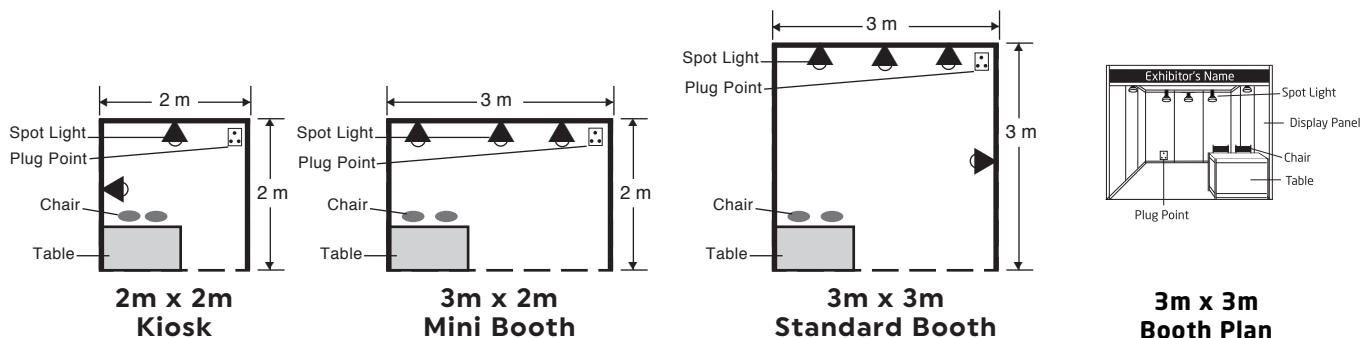

note:

1. No nailing, stickers or painting allowed on aluminium frames.
2. No nailing or painting allowed on panels.
3. Double-sided tape, stickers, placed by Exhibitors on panels must be removed by Exhibitors at the end of the exhibition.
4. Exhibitors can request for coloured panels at extra cost from the Official Contractor. This is subject to availability

### I. STANDARD SHELL SCHEME BOOTH includes

The Official Contractors will provide the following items for each shell scheme booth (2m x 2m) / (3m x 2m) and (3m x 3m)

**Fascia** : Red background with Exhibitor's name in English (max. 25 letters ) using white cut-out lettering.

**Wall Panelling** : Three side walls (white laminated panels) held by prefabricated aluminium system. In the case of corner booths it will be two side walls and two fascia boards.

	<b>Kiosk</b> (2m x 2m)	<b>Mini Booth</b> (3m x 2m)	<b>Standard Booth</b> (3m x 3m)
<b>Furniture :</b>	a. One information counter b. Two chairs c. One waste paper basket	a. One information counter b. Two chairs c. One waste paper basket	a. One information counter b. Two chairs c. One waste paper basket
<b>Lighting :</b>	Two LED Lamps (9 W)	Three LED Lamps (9 W)	Four LED Lamps (9 W)
<b>Power :</b>	1 Power socket (5 Amp)	1 Power socket (5 Amp)	1 Power socket (5 Amp)

### II. ADDITIONAL RENTAL FURNITURE & ELECTRICAL FITTINGS

In addition to items provided in the basic Standard Shell Scheme Booth, Exhibitors may require additional furniture/electrical items which can be supplied on a rental basis by the Official Contractor. Please complete the attached Form 2 and return to the Organiser by the deadline given.

## **B5. EXHIBITOR SOUND LEVEL**

TTF maintains an 80 decibel sound level for all exhibitors. This level has been identified as being a safe level for trade show demonstrations. To ensure a successful Trade Show for all exhibiting companies and their guests, Fairfest Media, as Show Management, reserves the right to closely monitor sound usage and, where necessary, restrict and possibly eliminate the music and other audio demonstrations in an exhibitor's booth at its discretion. Show Management's actions can include, but are not limited to, reviewing and adjusting all sound system and loud-speaker placements within an exhibit, restricting sound levels within a booth, and restricting demonstrations within a booth.

## **B6. CAUTIONARY NOTE:**

**Please go through the following rules carefully.  
Not adhering to the rules, will attract penalties.**

- **The maximum height of construction is 14 feet for bare space only booths (including platform height) & 8 feet for common wall and back wall.**
- **Approval of plan and elevation of the booth design is required to be taken from organizers by submitting the same 15 days prior to the show.**
- **Stalls constructed in contravention of the rules or not as per approved drawing are liable to be dismantled, and, in addition, will attract penalties**
- **No welding or cutting that may be flammable or sawing is allowed inside the hall**
- **Do not draw extra electricity load without written approval from the organizers**
- **Do not encroach in the passages inside the hall (Beyond Your Booth Periphery)**
- **No storage of materials behind the octonorm panels/booth**
- **No blocking the emergency exits in any way**

### C. RECORD OF ORDERS

(Put a ✓ if submitted)			Amount Rs / US\$	Last Date of Submission
				Kolkata
	FORM 1	Registration of outside Contractor		02.07.2023
	FORM 2	Fascia Board / Furniture / Electrical		02.07.2023
	FORM 3	Temporary Staff		02.07.2023
	FORM 4	Preferred Customer Pass	N A	02.07.2023
	FORM 5	Award Forms	N A	06.07.2023

Total payment committed :

Date : \_\_\_\_\_

- Note :
- 1) Prices are quoted in Indian Rupees (INR), Current rate of US\$ 1 = INR 82 approximately.
  - 2) Exhibitors are advised to make payment to and deal directly with individual suppliers/contractors concerned.
  - 3) This is for your record. Please retain it for future reference.

Deadline for Submission : 02 July, 2023

## FORM 1

For official use :  
Exhibitor :  
Received :

Fax or Mail To :  
**Fairfest Media Ltd.**  
25 C/1 Belvedere Road, Alipur  
Kolkata 700 027. India  
Tel : (91) (33) 4028 4028  
E-mail : contact@fairfest.in

Return within 02 July 2023

### APPLICATION FOR OUTSIDE CONTRACTOR - DAMAGE & PERFORMANCE BOND

(Please fill in this form if you plan to engage your own contractor instead of the Official Contractor for any booth design, decoration or construction work.)

Exhibitor's Name

Sq. mtr. booked

This upper portion of the application form should be completed by the contractor appointed by the individual Exhibitor, and must be accompanied by a demand draft (issued by the contractor) made payable to "Fairfest Media Ltd." which will be held against possible damages to the Exhibition Hall, and/or the disposal of extra waste left on site after the event (if any).

**BOOTH HEIGHT LIMIT :** The maximum height of construction is 14 feet for bare space only booths (including platform height) & 8 feet for common wall and back wall.

All bare space exhibitors are requested to send their designs and take prior approval from the organizer.

#### Damage & Performance Bond

**(1)** A Damage & Performance Bond of **INR 25,000 for booths below 100sqm or INR 50,000 for booths above 100sqm** must be paid in cash or by demand draft by the booth contractor to the Organisers when they register at the exhibition site for booth possession. This will be held against damages to the venue, and/or the disposal of booth construction waste left on-site after the event. Any breach of the organisers/venue's regulations may also cause the deposit to be forfeited.

**(2)** It is the individual booth contractor's responsibility to remove all packing and waste materials from the exhibition hall during both move-in and move-out. Garbage & waste materials from decoration work must not be discarded into the aisles & must be cleared. All material used must be removed during move-out and this must be done safely (no pushing over high pieces of booth, no smashing of glass panels etc). Failure to comply will result in the Damage & Performance Bond being totally forfeited.

**(3)** The Damage & Performance Bond will be refunded by showing the receipt after the exhibition subject to the clearance of the site by the contractors and no damage or garbage being recorded by the exhibition centre management and the organisers.

**(4) Organisers reserve the right to deduct an actual and appropriate amount for damages to the hall structures/venue, made by the exhibitor or their design & handling agencies' staff during build-up, show days and dismantling time, from the Damage & Performance Bond paid by the exhibitor.** This is to ensure all the rules & regulations are abided by and to cover any damage arising directly or indirectly from infringement. This is without prejudice to any additional claims the organisers may have on the exhibitor if the damages exceed the bond amount. Balance amount if any, will be returned if no damage is found.

On receipt of this Form and the deposit payment CONTRACTOR PASSES will be issued. Only holders of CONTRACTOR PASSES will be allowed access to the site.

Please supply CONTRACTOR PASSES : No. required : \_\_\_\_\_

The deposit will be refunded after the exhibition subject to the clearance of the site by the contractors and no damage being recorded.

Contractor's Name : \_\_\_\_\_

Address : \_\_\_\_\_

Contact Person : \_\_\_\_\_ Designation \_\_\_\_\_

Tel : \_\_\_\_\_ Fax : \_\_\_\_\_ Signee's Name : \_\_\_\_\_

Exhibitor's signature/company stamp \_\_\_\_\_ Dat \_\_\_\_\_

N.B. : Electrical installations must be carried out by the Official Contractor only.

**Approval of plan and elevation of the booth design is required to be taken from organizers by submitting the same 15 days prior to the show. Stalls constructed in contravention of the rules ( see point nos. B1 to B6 on page 4-6, specially the cautionary note) or not as per approved drawing, are liable to be dismantled, and, in addition, will attract penalties.**

Please make copy for your own reference



### FORM 3

For Official use : Exhibitor : Received :
---

**Return within 02 July 2023**

Fax or Mail To : **Fairfest Media Ltd.**  
 25 C/1 Belvedere Road, Alipur  
 Kolkata 700 027. India  
 Tel : (91) (33) 4028 4028  
 E-mail : contact@fairfest.in

### TEMPORARY STAFF

Temporary staff may be hired through a manpower agency on daily basis. If you are not requiring staff through the whole period, please indicate the dates that temporary staff will be needed.

We require :

Service : Information counter personnel

(a) Daily rate per person : Rs. 1150/-

(b) For the following dates (July 2023)

14	15	16	all 3 days

Put a ✓ :

(c) Number of persons required on the above dates :

(d) Total amount payable (@ Rs.1150/- per person per day) : Rs.

**# Add GST @ 18%**

#### EXHIBITOR'S AUTHORISATION

Company Name : \_\_\_\_\_

Company Address : \_\_\_\_\_

Tel : \_\_\_\_\_ Fax : \_\_\_\_\_

Name : \_\_\_\_\_ Designation : \_\_\_\_\_

Signature : \_\_\_\_\_ Date : \_\_\_\_\_

**Please make copy for your reference.**

## D. EXHIBITOR AWARD PROGRAMME

Deadline for submission is 7 days before the opening day.

Dear participant :

Thank you for participating in TTF Kolkata. This year's event promises to be a resounding success due to your support!

Entry for all awards are on the following five pages. There is no entry fee but entry forms **must be completed and received 7 days before the opening of TTF**. This is to ensure all entries receive proper consideration. Fax or mail the completed forms to Fairfest. Winners will be notified at the exhibition (TTF). All decisions made by the Judging Panel are final.

**Award Categories** (also see attached Entry Forms)

**D1. BEST PRINT PROMOTIONAL MATERIAL** (two categories : NTO or Tour Operator, Airline, Car Rental Company or Hotel) - judging committee will judge all categories of printed material including posters, leaflets, brochures, pamphlets etc. as part of overall print campaign. Consideration will be made for design concept/creativity as well as print quality. Promotional material must be submitted with completed entry form.

**D2. MOST PROMISING NEW DESTINATION** (two categories: India, International) - Candidates will provide brief description of new destination on entry form. Consideration will be made for construction of new facilities, offerings of surrounding locale environment, and wealth of local features (entertainment or other).

**D3. MOST INNOVATIVE PRODUCT** - judged with respect to providing an overall educational service, whether educating visitors on an indigenous population/cultural heritage or promotion of local environmental awareness.

**D4. MOST EXCLUSIVE LEISURE PRODUCT** - targeted to upscale clientele, where cost is no bounds. Judged with respect to comprehensiveness and uniqueness of overall package.

**D5. BEST VALUE LEISURE PRODUCT** - product should be comprehensive but maintain cost-effectiveness and be intriguing to general populace (not targeted to select upscale market).

In addition, we have Stall Awards. These awards shall be judged on site. No entry forms are required in advance for these.

**Thank you again for your time and participation. We look forward to seeing you at TTF.**

Fairfest Media Ltd.

## FORM 5A

Deadline : 7 days before opening of fair

# AWARDS PROGRAMME

Kolkata

## BEST PRINT PROMOTIONAL MATERIAL AWARD

Details

Name of entrant : \_\_\_\_\_

Designation : \_\_\_\_\_

Name of company : \_\_\_\_\_

Address : \_\_\_\_\_

\_\_\_\_\_

Telephone : \_\_\_\_\_ Fax : \_\_\_\_\_

### Category (tick one)

Govt.-Sector/NTO

Private Sector Participant

Rules and Procedures

1. Please attach three copies of all print and promotional material you will use at TTF (including brochures, posters, leaflets, pamphlets, etc.)
2. Please attach separate form on company letterhead which details target audience, objectives of print campaign, results or expected results.
3. Completed entry forms must be received before 7 days of the fair :

TTF Awards Programme

#### **Fairfest Media Ltd.**

25C/1 Belvedere Road, Alipur

Kolkata 700 027. India

Tel : (91) (33) 4028 4028

E-mail : contact@fairfest.in

4. All decisions made by Judging Panel are final.

## FORM 5B

Deadline : 7 days before opening of fair

# AWARDS PROGRAMME

Kolkata

## MOST PROMISING NEW DESTINATION AWARD

Details

Name of entrant : \_\_\_\_\_

Designation : \_\_\_\_\_

Name of company : \_\_\_\_\_

Address : \_\_\_\_\_

\_\_\_\_\_

Telephone : \_\_\_\_\_ Fax : \_\_\_\_\_

### Region (tick one)

India

International

Rules and Procedures.

1. Please attach separate form on company letterhead which gives brief description of new destination on entry form. Details should include:
  - description of new facilities constructed, offerings of surrounding locale/ environment and wealth of local features (entertainment or other).
  - target market
  - statistics on tourism to the destination in recent years, as well as statistics on expected tourism to the region if available.

2. Completed entry forms must be received before 7 days of the fair :

TTF Awards Programme

#### **Fairfest Media Ltd.**

25C/1 Belvedere Road, Alipur

Kolkata 700 027, India

Tel : (91) (33) 4028 4028

E-mail : contact@fairfest.in

3. All decisions made by Judging Panel are final.

## FORM 5C

Deadline : 7 days before opening of fair

# AWARDS PROGRAMME

Kolkata

## MOST INNOVATIVE PRODUCT AWARD

### Details

Name of entrant: \_\_\_\_\_

Designation: \_\_\_\_\_

Name of company: \_\_\_\_\_

Address: \_\_\_\_\_

\_\_\_\_\_

Telephone : \_\_\_\_\_ Fax: \_\_\_\_\_

### Rules and Procedures

1. Please attach separate form on company letterhead which gives brief description of your product and how it provides overall educational service, such as educating visitors on an indigenous population/cultural heritage or promotion of local environmental awareness.

Details should include:

- historical development of programme or project
- source of funding for project or programme
- target market
- results achieved in increasing awareness of programme or project's cause

2. Completed entry forms must be received before 7 days of the fair :

TTF Awards Programme

Fairfest Media Ltd.

25C/1 Belvedere Road, Alipur

Kolkata 700 027. India

Tel : (91) (33) 4028 4028

E-mail : [contact@fairfest.in](mailto:contact@fairfest.in)

3. All decisions made by Judging Panel are final.

## FORM 5D

Deadline : 7 days before opening of fair

# AWARDS PROGRAMME

Kolkata

## MOST EXCLUSIVE LEISURE PRODUCT AWARD

### Details

Name of entrant: \_\_\_\_\_

Designation: \_\_\_\_\_

Name of company: \_\_\_\_\_

Address: \_\_\_\_\_

\_\_\_\_\_

Telephone: \_\_\_\_\_ Fax: \_\_\_\_\_

### Rules and Procedures

1. Please attach separate form on company letterhead which details:
  - brief description of product
  - target market (should be geared towards upscale, select market)
  - reasons why this product offers the most comprehensive or unique way to access destination

Please also attach brochures, pamphlets, or other supporting documentation if available.

2. Completed entry forms must be received before 7 days of the fair :

TTF Awards Programme

**Fairfest Media Ltd.**

25C/1 Belvedere Road, Alipur

Kolkata 700 027. India

Tel : (91) (33) 4028 4028

E-mail : contact@fairfest.in

3. All decisions made by Judging Panel are final.

## FORM 5E

Deadline : 7 days before opening of fair

# AWARDS PROGRAMME

Kolkata

## BEST VALUE LEISURE PRODUCT AWARD

### Details

Name of entrant: \_\_\_\_\_

Designation: \_\_\_\_\_

Name of company: \_\_\_\_\_

Address: \_\_\_\_\_

\_\_\_\_\_

Telephone: \_\_\_\_\_ Fax: \_\_\_\_\_

### Rules and Procedures

1. Please attach separate form on company letterhead which details:
  - brief description of product
  - cost of product to various markets (product should be targeted to large market)
  - reasons why this product is the best value of its kind

Please also attach brochures, pamphlets, or other supporting documentation if available.

2. Completed entry forms must be received before 7 days of the fair :

TTF Awards Programme

**Fairfest Media Ltd.**

25C/1 Belvedere Road, Alipur

Kolkata 700 027. India

Tel : (91) (33) 4028 4028

E-mail : contact@fairfest.in

3. All decisions made by Judging Panel are final.

## E. FINAL CHECKLIST & SHOW IMPLEMENTATION

### FINAL CHECKLIST

- Furniture ordered for exhibition booth and/or trade show contractor hired?
- Hotel accommodation and travel bookings made?
- Informational materials prepared for the general public?
- Business cards printed?
- How will the packaged material be brought to the booth?
- Arrangement for temporary staff made?
- What invoices are still outstanding?

### SHOW IMPLEMENTATION

During TTF it is important that your stand personnel converse professionally with customers. These interactions must be documented properly to collect information for professional trade show follow-up.

#### 1. Conversation with customers

- Every opportunity to make contact is priceless and must be converted to dialogue with a great deal of attention and willingness.
- Even seemingly disinterested customers present a window of opportunity for fruitful communication.
- Understand the visitor's busy schedule and compress your sales pitch accordingly.
- Leave room for the visitors to explore, instead of overwhelming them with attention.
- Recognize the interests of the visitor and build your conversation around it.

#### 2. Documentation

Each conversation forms the basis for your trade show follow-up and hence must be documented by stand personnel whenever a visitor shows keen interest.

- When a business card is available do not ask for information already mentioned there.
- Only begin taking notes after a short warm-up phrase.
- Because your notes are not secret, allow the person concerned to see what you write down.
- Use copies of the enclosed "Conversation Record" for evaluating significant contacts.

#### 3. Follow-up

In no later than 10 days after TTF, the following activities when efficiently handled directly influence the business decisions of important contacts:

- Thank-You mailings
- Phone calls to initiate contacts
- Business proposals
- Live up to the promises made

**WE WISH YOU SUCCESS IN THE UPCOMING EVENTS  
&  
HOPE YOU FIND THESE GUIDELINES USEFUL**

**YOUR TTF TEAM**

# Conversation Record

Visitor's Name : \_\_\_\_\_

Designation : \_\_\_\_\_

Company : \_\_\_\_\_

Address : \_\_\_\_\_

\_\_\_\_\_

\_\_\_\_\_

Phone No. : \_\_\_\_\_

Business Card Attached?

Customer Category

New

Old

Potential

Other

Interests : \_\_\_\_\_

\_\_\_\_\_

\_\_\_\_\_

\_\_\_\_\_

Results : \_\_\_\_\_

\_\_\_\_\_

\_\_\_\_\_

Special Note : \_\_\_\_\_

\_\_\_\_\_

\_\_\_\_\_

\_\_\_\_\_

Staff Member :

Date :